



INSTALLATION AND MAINTENANCE INSTRUCTIONS I

This publication contains the installation, operation, and maintenance procedures for standard units of the Model RV, RCV gravity ridge ventilators. Catalog MB-96 provides additional information describing the equipment, performance, available accessories and specification data.

For additional safety information refer to AMCA publication 410-96, Safety Practices for users and installers of Industrial Commercial Fans.

All publications listed above can be obtained from Romla Ventilator Company



**MODEL RV
INDIVIDUAL RIDGE VENTILATOR**

RECEIVING AND INSPECTION

Carefully inspect the unit for any damage and shortage immediately upon receipt of the unit and record on the Delivery Receipt any visible sign of damage.

MODEL RV INSTALLATION

1. Place unit over roof opening with end cap flashing in place. Closure strip (matching roofing) with mastic is required between ventilator flashing and roof sheeting.
2. Secure unit and flashing to roof. Fasteners to suit roof construction and material (not by Romla).
3. Fasten end cap to flashing with #8x1/2 sheet metal screws.
4. Caulk end cap flashing at end cap and side flashing.

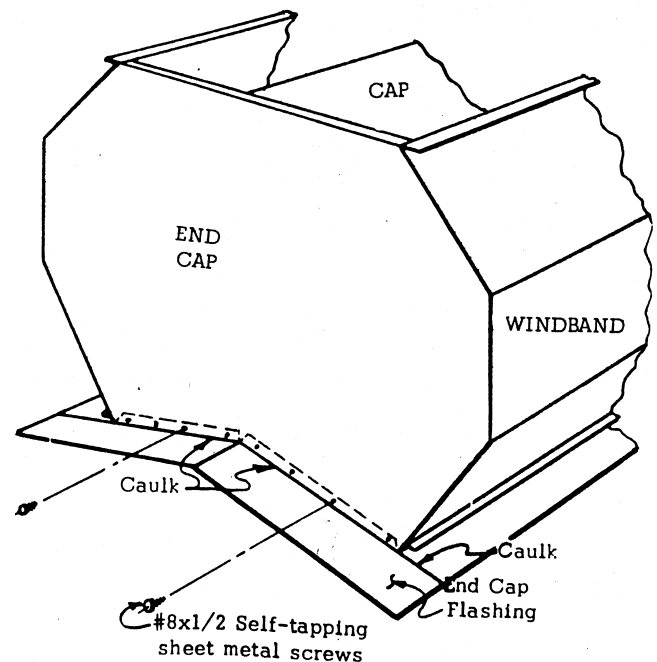

MODEL RCV CONTINUOUS RIDGE VENTILATOR INSTALLATION

1. Install first section containing one end cap over roof opening. Closure strip (matching roof), with Mastic is required between ventilator flashing and roof sheeting. If ventilator has a Damper, the Damper operator will be contained in this unit.
2. Bolt Connecting Bar Splices to the Connecting Bar. Caulk flashing and cap join plates at both edges and insert on ends of Flashing. Slip Windband, and Damper Join Plates to their respective positions shown on the Join Plate drawings. On Size 24" only, Windband and Cap Join Plates are to be fastened with #8x1/2" Tek Sheet Metal Screws (Self Drilling) after joining of sections
3. Bring unit #2 near enough to start into these Join Plates. Then slip units together with damper travel always toward the operator. Each 10' section is actually 9'-11-1/2" long therefore exactly a 1/2" gap should exist between, which are covered with the Join Plates

4. Continue as above with other sections until entire ventilator is completed.
5. If a continuous run contains more than one damper operator, see replacement guide for location. A connecting bar splice is not required between this operator unit and previously installed unit.
6. Ventilator may be secured to the building as the units progress, or may be fastened after all sections are joined together. Alignment of all sections must be reasonably straight, otherwise damper may bind.
7. Caulk all Join Plates and End Cap Flashings to prevent leakage.
8. Bolt other end of Connecting Bar Splice from below with 1/4-20x5/8 Machine Bolts. Check for damper operation.

MAINTENANCE

After final Installation the gravity ventilator requires minimal maintenance. To assure proper free area for optimal ventilation, optional accessories such as insect screens require periodic cleaning to remove dust and dirt.

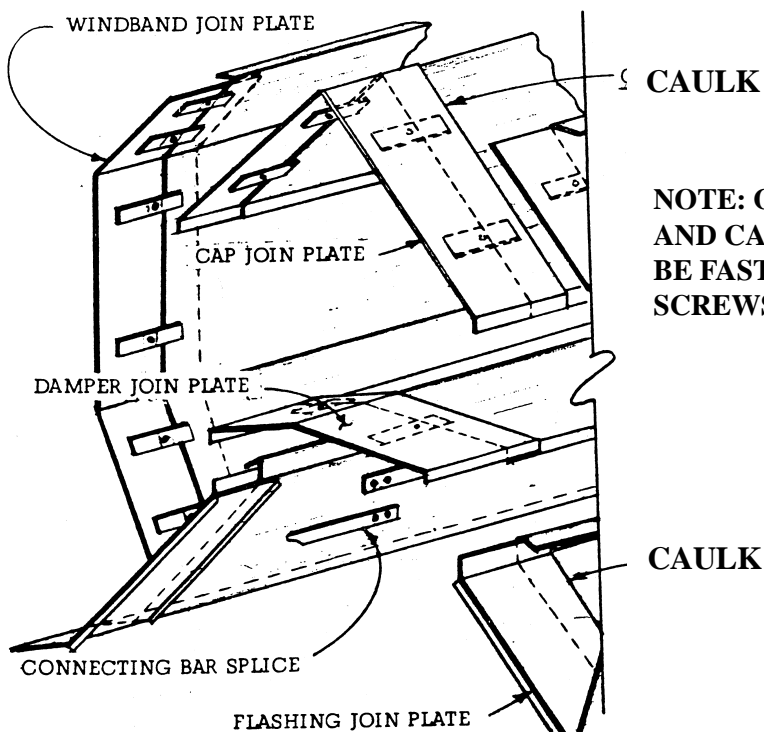

NOTE: ON 24" SIZE, WINDBAND AND CAP JOIN PLATES ARE TO BE FASTENED WITH #8X1/2" TEK SMS SCREWS